

8x ϕ 5.3 (inkl. 4x Schraube M6x20 gewindefurchend)
 8x ϕ 5.3 (incl. 4x Screw M6x20 self-tapping)

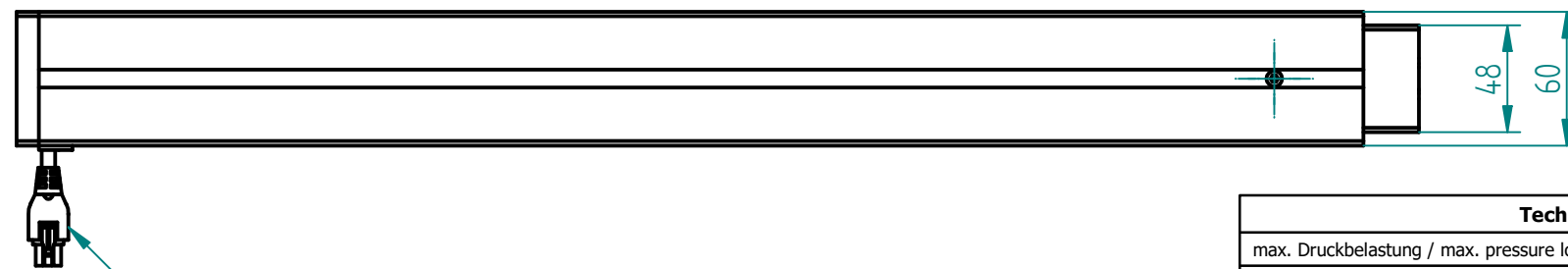

Motorkabel 1.8 m
 Motor cable 1.8 m

ausgefahren
 extended

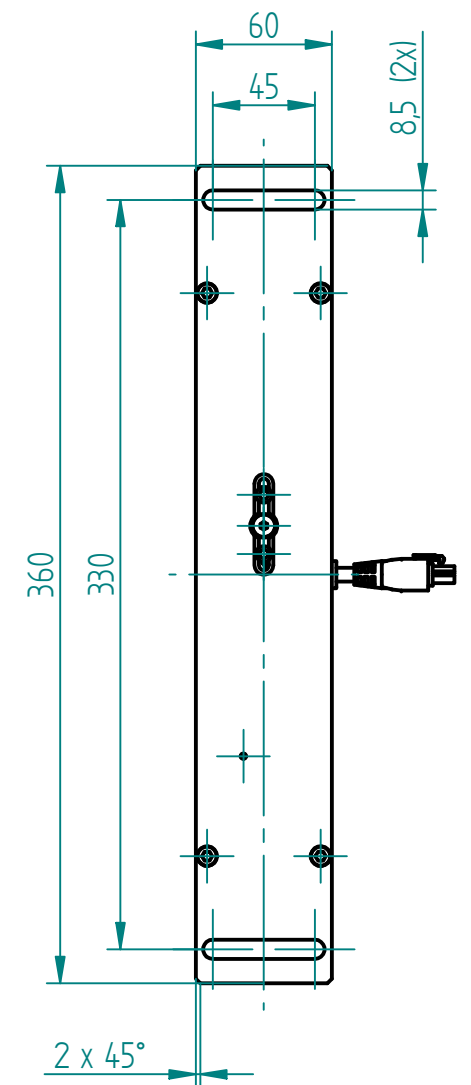
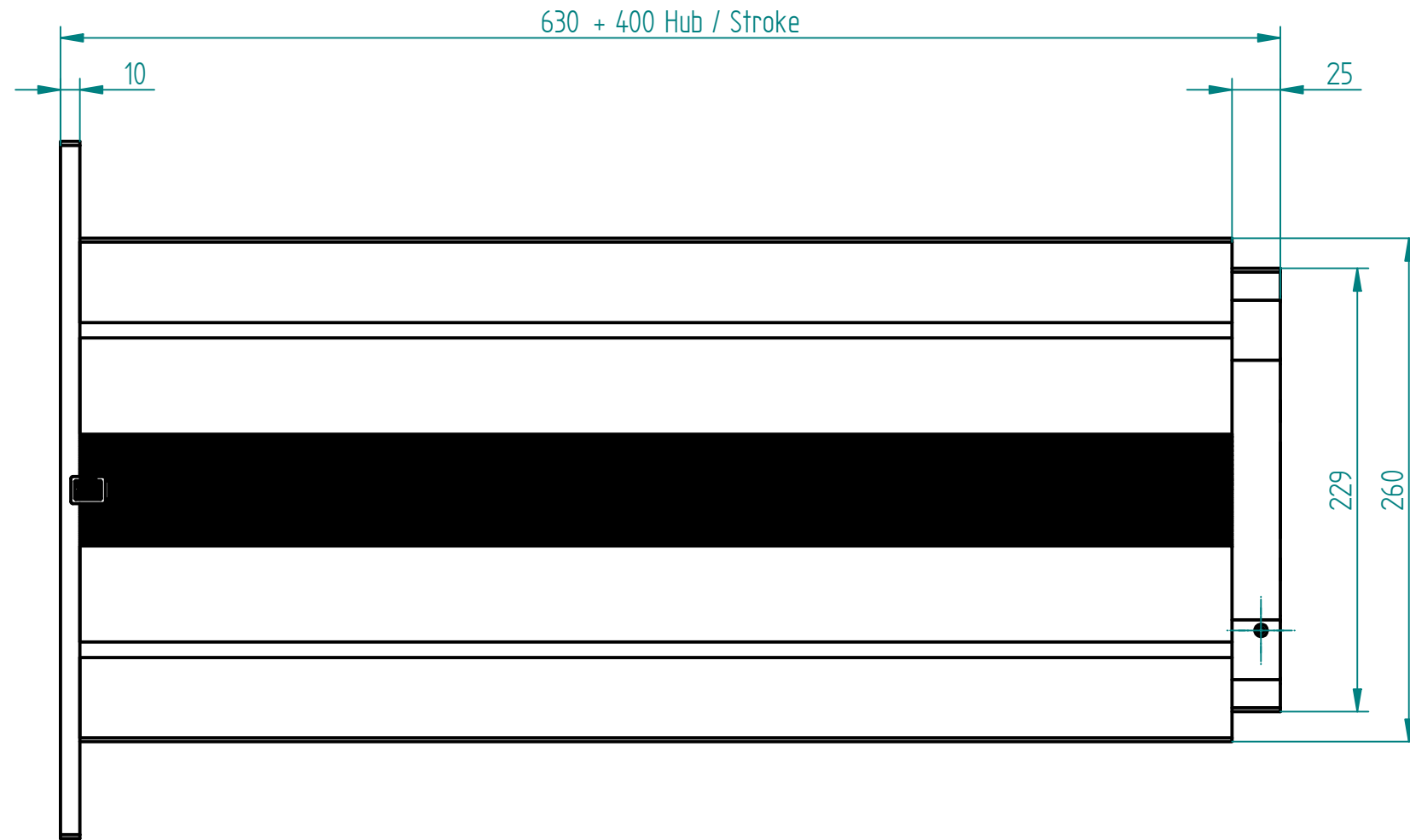
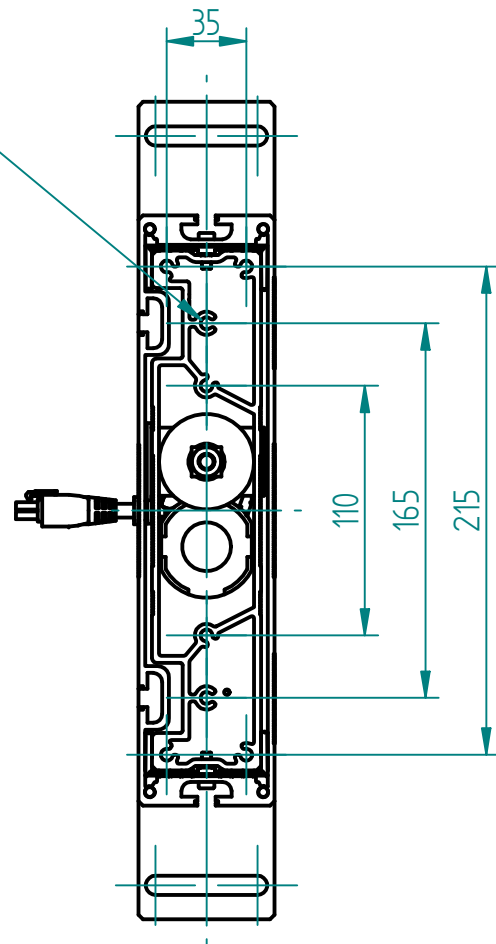
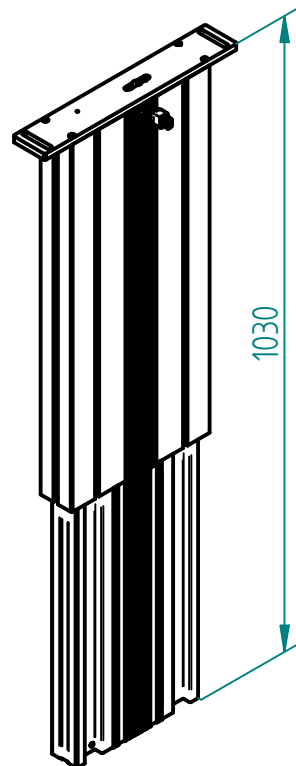

eingefahren
 retracted

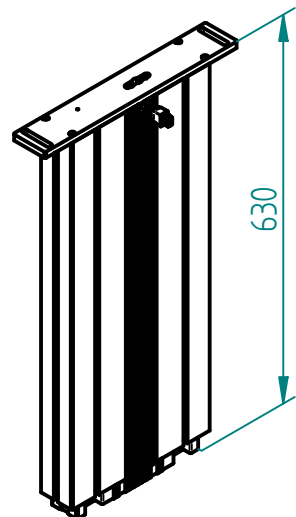

X
 Y

Nutengeometrie
 T-Slot geometry

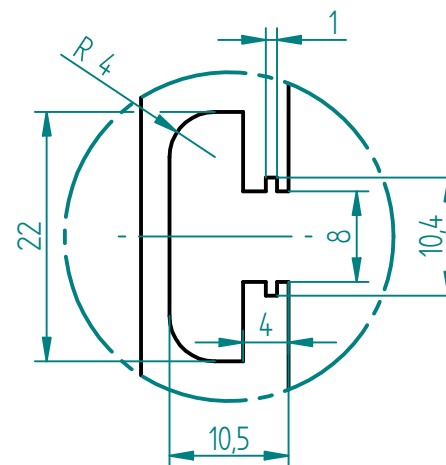

Technische Daten / technical specifications

max. Druckbelastung / max. pressure load	2'000 N
max. Systembelastung / max. system load	abhängig von Steuerung / depending on control box
max. statische Zugbelastung / max. static tensile load	500 N
max. dynamische Zugbelastung / max dynamic tensile load	50 N
max. Hub / max. stroke	400 mm
Hubgeschwindigkeit / lifting speed	12 mm/s
max. stat. Biegemoment / max. static bending moment	Mbx stat. 1'200 Nm / Mby stat. 450 Nm
max. dyn. Biegemoment / max. dynamic bending moment	Mbx dyn. 550 Nm / Mby dyn. 200 Nm
Aluminiumprofile / aluminium profiles	farblos eloxiert / colorless anodized
Führungsart / type of guidance	Gleitführung (Kunststoff) / slide (plastics)

06	11.12.2019	bema	1100: optisch Änderung: Langloch für Motor in Adapterplatte
05	26.03.2019	tiho	1050: Innenprofil neu ohne T-Nut, Bohrbild mit Eckbohrungen
04	23.03.2018	bm	0995: Bohrabstände neu 110.5 & 165.5, alt 110 & 165
03	02.05.2017	bm	0937: Neue Adapterplatte mit Langloch
02	20.11.2015	sc	0839: beidseitig je 4x M8 Bohrungen (statt 6x Ø6.5)
01	17.02.2015	ah	0807: Aussenprofil um 10mm gekürzt

Index	Datum / Date	Name	Änderungsmittelung / notification of change
GEZEICHNET / DRAWN	13.10.2014	sc	GEWICHT / WEIGHT 10.777 kg
GEPRÜFT / CHECKED	13.10.2014	ah	MABSTAB / SCALE 1:5

