

ausgefahren
extended



eingefahren
retracted



Nutengeometrie / T slot geometry

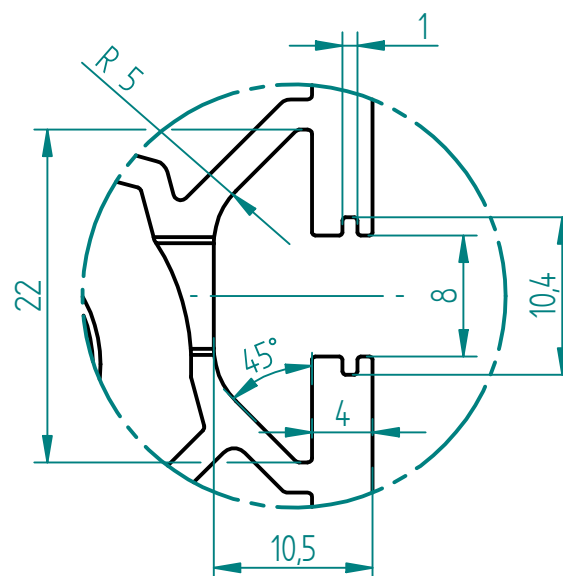

Technische Daten / technical specifications

max. Druckbelastung / max. pressure load	1'250 N
max. Zugbelastung / max. tensile load	1'250 N
max. Systembelastung / max. system load	abhängig von Steuerung / depending on control box
max. Hub / max. stroke	400 mm
Hubgeschwindigkeit / lifting speed	abhängig von Steuerung / depending on control box
max. stat. Biegemoment / max. static bending moment	Mb stat. 200 Nm
max. dyn. Biegemoment / max. dynamic bending moment	Mb dyn. 80 Nm
Aussenprofil / outer profile	Aluminium / aluminum
Innenprofil / inner profile	Stahl / steel
Führungsart / type of guidance	Gleitführung (Kunststoff) / slide (plastics)

Index	Datum / Date	Name	Änderungsmittlung / notification of change
GEZEICHNET / DRAWN	22.01.2020	tiho	GEWICHT / WEIGHT 3.612 kg
GEPRÜFT / CHECKED	22.01.2020	bema	MABSTAB / SCALE 1:2

